

AKO Temperature Regulator selfactuated

BT 226G0120-GB

AKO
Regelungstechnik

AKO Three-Way-Temperature Regulator Type Series 226G0120

Deliverable sizes: 40, 50, 65, 80, 100, 125, 150 mm

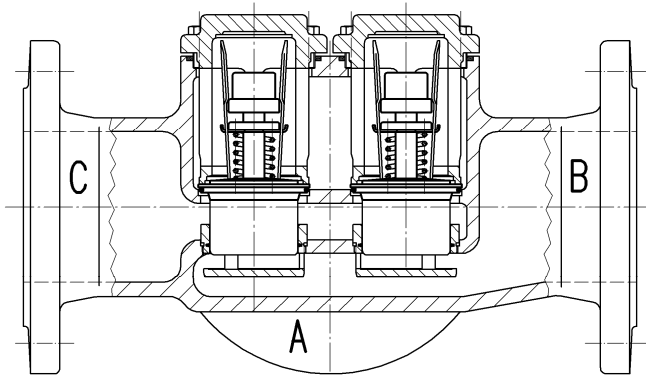

Technical Data:

Material:	
- Body	EN-GJS-400-15
- Inner Parts	SS / Brass
Thermostat	237.0120-xxx-0
Sealing Kit	NBR
Operating Pressure	up to 16 bar
Adm. Differential Pressure	up to 16 bar
Nominal Pressure	PN 16
Connection	Flange EN 1092-2 form B

Installation:

The installation can be done selectively as follows:

as divider

path A: from motor
path B: to bypass
path C: to cooler

as mixing valve

path C: from cooler
path B: from bypass
path A: to motor

The paths have been marked on the connections.
The temperature regulator may be installed in all position.

Deliverable temperature ranges

05 – 15 °C	35 – 43 °C	57 – 66 °C	74 – 82 °C	93 – 103 °C*
14 – 26 °C	37 – 47 °C	60 – 69 °C	77 – 85 °C	102–113 °C*
20 – 30 °C	39 – 50 °C	62 – 71 °C	79 – 88 °C	
27 – 37 °C	43 – 54 °C	66 – 74 °C	82 – 93 °C	
29 – 40 °C	51 – 60 °C	68 – 78 °C	85 – 96 °C*	
32 – 41 °C	54 – 63 °C	71 – 79 °C	88 – 99 °C*	

Max. continuous temperature 25 °C above fully open temperature.
*maximal operating temperature 120 °C

Application

AKO Temperature Regulators are suitable for the stabilization of temperatures of media (e. g. water, oils, etc.) and are even applicable as dividing units or mixing valves. Depending on their construction they are distinguished by their low need of maintenance, particular operating convenience and resistance to pressure. A replacement of inner parts is possible on the spot without having to remove the regulating valve from the piping. A faulty assembly can be excluded. The temperature regulators could be assembled in each fitting position.

Function

AKO Temperature Regulators are being equipped with easily replaceable internal wax-filled thermostats that absorb the temperature of the medium surrounding them at the measurement point namely into expansion and thus a change in path or length (the valve stroke). AKO Temperature Regulators do not require any auxiliary energy. At rising temperature and on excess of the opening temperature, the tube slider is being lifted off on the valve seat and opening path A to C, with the path A to B locking simultaneously in the same ratio. The change is being performed in proportion to the change of temperature of the passing medium.

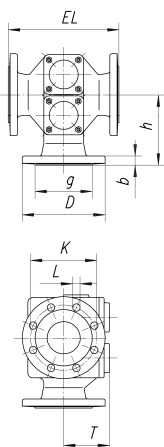

order-no.	DN	D [mm]	g [mm]	b [mm]	h [mm]	T [mm]	EL [mm]	K [mm]	L [mm]	pieces of thermostats	weight [kg]	KVs [m³/h]
226G0120-040	40	155	88	20	102	145	178	110	4x19	1	13,0	24,64
226G0120-050	50	165	102	23	150	135	225	125	4x19	1	17,5	38,80
226G0120-065	65	190	122	25	165	116	254	145	4x19	2	27,0	62,80
226G0120-080	80	200	138	22	171	108	267	160	8x19	2	27,0	85,95
226G0120-100	100	254	158	31	217	125	403	180	8x19	4	55,0	156,70
226G0120-125	125	250	188	26	241	182	489	210	8x19	6	64,0	212,00
226G0120-150	150	285	212	26	254	182	489	240	8x23	8	79,0	299,00