

AKO Temperature Regulator selfactuated

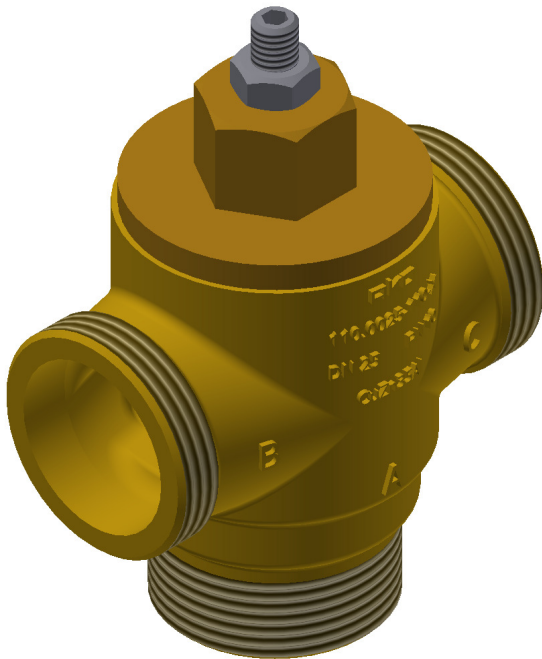

AKO Three-Way Temperature Regulator
Type Series 226.0651-100 with manual override



Technical Data

Material:	
- Valve body	CuZn35Al
- Inner parts	Brass/SS
Thermostat	237.5100-xxx-0
Sealing Kit	NBR
Operation pressure	up to 10 bar
adm. Differential pressure	max. 10 bar
Connection	external thread G 1 1/2"
Weight	1 kg

Manual override for the mechanical opening of the cooling path in case of any failure of the thermostat.

The emergency adjustment is not to be used to adjust the set point when the thermostat is working properly!

Installation:

The installation can be done selectively as follows:

as divider

path A: from motor

path B: to bypass

path C: to cooler

as mixing valve

path C: from cooler

path B: from bypass

path A: to motor

The paths have been marked on the connections.

The temperature regulator may be installed in all positions.

Deliverable temperature ranges:

04 - 11 °C	39 - 49 °C	60 - 71 °C	93 - 101 °C*
22 - 30 °C	43 - 54 °C	68 - 77 °C	97 - 107 °C*
29 - 40 °C	49 - 60 °C	76 - 88 °C	101 - 121 °C**
35 - 46 °C	54 - 65 °C	82 - 93 °C	

Max. continuous temperature 15°C above fully open temperature.

*maximal operating temperature 120°C

**maximal operating temperature 125°C

Application

AKO Temperature Regulators are suitable for the stabilization of Temperatures of media (e. g. water, oils, etc.) and are even applicable as dividing units or mixing valves. Depending on their construction they are distinguished by their low need of maintenance, particular operating convenience and resistance to pressure. A replacement of inner parts is possible on the spot without having to remove the regulating valve from the piping. A faulty assembly can be excluded. The temperature regulators could be assembled in each fitting position.

Function

AKO Temperature Regulators are being equipped with easily replaceable internal wax-filled thermostats that absorb the temperature of the medium surrounding them at the measurement point namely into expansion and thus a change in path or length (the valve stroke). AKO Temperature Regulators do not require any auxiliary energy. At rising temperature and on excess of the opening temperature, the tube slide is being lifted off of the valve seat and opening path A to C, with the path A to B locking simultaneously in the same ratio. The change is being performed in proportion to the change of temperature of the passing medium.

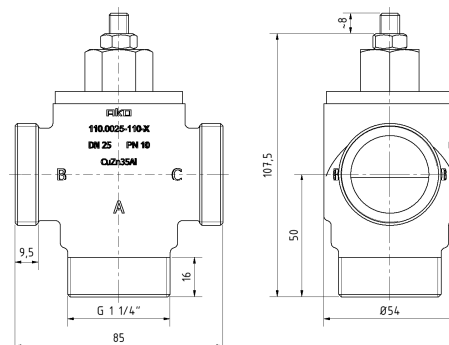

AKO Regelungstechnik GmbH & Co KG

Friedrich-Sertürner-Straße 14 • D-51377 Leverkusen • Tel.: +49 (0) 214 / 840599-0 • Fax: +49 (0) 214 / 840599-29

eMail: info@akomail.de • Web: <http://www.ako-regelungstechnik.de>

12.11.2018, MB