

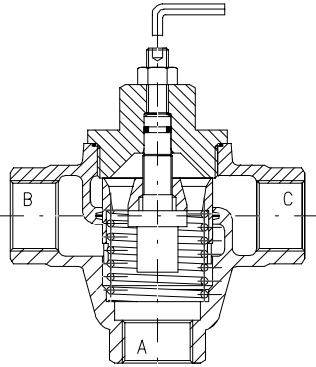

AKO Three-Way Thermostat with interior thermostat Types 226.0601, 2270601, 227.0701, 227.0705, 227.0710



1. General

AKO Thermostats can be used in all branches of industry where systems which need to be cooled need to be controlled. AKO Thermostats ensure a great degree of operational security, have proven to be resistant to faults and are especially service friendly. The AKO Thermostats require no auxiliary energy whatsoever.

2. Application

AKO Thermostats of the series described are suitable to keep the temperatures of a medium constant (e.g. water, oils etc.) and can be used as dividers or mixing valves. They are characterised by the fact that they are relatively maintenance free, are very service friendly and that they are not sensitive to pressure. The inner parts can be exchanged immediately without

having to disassemble the regulating valve from the pipe.

3. Function

AKO Thermostats are equipped with interior, easily exchangeable thermostats which register the temperature of the medium surrounding them at the measuring point (point of installation) and convert it into another physical dimension, namely extension and therefore into a change in distance or length (the valve stroke). With increasing temperature and exceeding the start of the opening, the tubular slider is lifted off the seat of the valve and opens the path from A to C, at the same time and in the same ratio the path from A to B is closed. The change in path occurs proportionally to the change in temperature of the medium flowing through. The descriptions A, B and C have been cast on the housing of the thermostat. The thermostats can be installed in every position.

4. Emergency manual adjustment.

The thermostats described here are all equipped with an emergency manual adjustment in order to comply with the safety requirements - especially those of the classification companies. **This emergency manual adjustment is not to be used for adjustment during automatic operation.** If the thermostat fails, the control valve can be used as a manually operated three-way valve via the emergency manual adjustment and therefore can be set in any position until the thermostat can be repaired or replaced.

5. Operation of the emergency manual adjustment

On delivery, the adjusting screw of the manual adjustment is secured in the starting position with a counter nut. If the thermostat fails, this counter screw is released and the adjusting screw is adjusted in a clockwise direction using the offset screw driver DIN 911 which is included in delivery. In doing so the tubular slider above the pressure plate is opened to the cooling path (C), and at the same time the short circuit path (B) is throttled. Between both end positions any position of the tubular slider is possible so that whilst monitoring the thermometer the operating temperature can be reached. You must make sure that after every adjustment the counter nut is fastened tightly again. When installing a new thermostat the adjusting screw must be put back into its original position so that the path to the cooler (C) is not mechanically opened first, as this gap cannot be closed again by the automatic system.

6. Installation

- 6.1 Rinse the pipes well before the control valve is installed.
- 6.2 Remove the connecting stoppers for the device from the input and output openings of the valve
- 6.3 Do not over tension and twist the control valve when connecting it to the pipes
- 6.4 The control valve is inserted



6.4.1 To regulate the outgoing temperature of the medium as a flow divider or flow separator

- A from the motor
- B to the motor (by-pass)
- C to the cooler

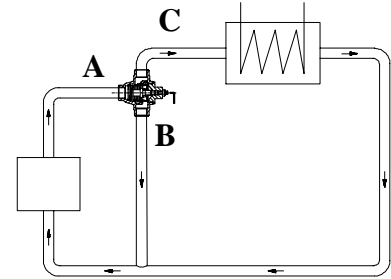

6.4.2 To regulate the input temperature of the medium as flow joiner or mixer, for example

- A from the cooler
- B from the motor (by-pass)
- C to the motor

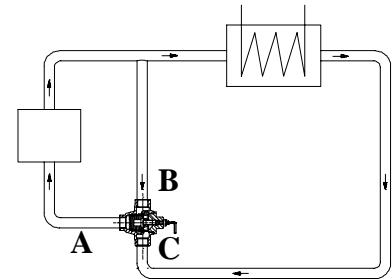

The path descriptions A, B and C have been cast on the housing

7. Maintenance

AKO Thermostats are virtually maintenance free. However, if the medium contains pollutants or deposits occur in the control valve it may be necessary to clean the control valve at large intervals.

8. Exchanging a thermostat

- 8.1 Close the valve off to all sides and remove all pressure (Watch the temperature!)
- 8.2 Loosen the lid and remove it. Watch out for the opposing pressure-safety spring !
- 8.3 Pull out the thermostat.
- 8.4 Check the interior of the housing for any dirt and if necessary clean it.
- 8.5 Insert a new thermostat with tubular slider.
- 8.6 Check the O-ring of the lid and if necessary renew it.
- 8.7 Put the lid back on and screw tight.
- 8.8 Open closing valves

9. Temperature ranges available

35 - 46 °C	49 - 60 °C	68 - 77 °C	93 - 101 °C

10. Table of dimensions

order-no.	DN	t	EL	H	h	B	SW	weight kg	Qm ³ /h
226.0601-050	R 1/2"	17	110	120	55	61	32	1,6	2,0
226.0601-075	R 3/4"	17	110	120	55	61	32	1,5	3,5
226.0601-100	R 1"	21	115	130	65	67	50	2,1	5,5
226.0601-125	R 1 1/4 "	21	115	130	65	67	50	1,9	10,0

